

**ACOUSTIC DOOR SEALS**

Acoustic sealing components for use in single timber door sets. Typical noise reduction achieved by using the combination of perimeter and threshold seals detailed here is 31dB.

Door perimeter seals, comprising a surface fitted aluminium carrier supporting a silicon rubber, compression bulb seal. The carrier strip is screw fixed to the stops at the head and jambs. All screw fixings are within adjusting slots, and concealed beneath a charcoal grey cover strip. The aluminium extrusion is available silver or bronze anodised.

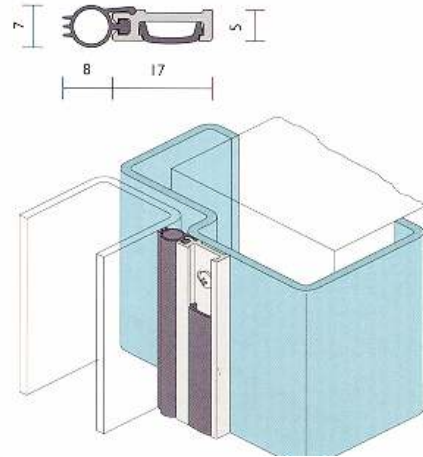

Size:	Finish	Code:
1000mm	Silver	<b>IB4010,SA</b>
2250mm	Silver	<b>IB4022,SA</b>
1000mm	Bronze	<b>IB4010,BA</b>
2250mm	Bronze	<b>IB4022,BA</b>

Automatic door base seals. An extruded aluminium inverted channel, housing and spring loaded carrier with silicon rubber compression seal. The carrier section is lowered when the door closes against the jamb, and lifts to prevent drag as the door is opened. Supplied in a variety of standard lengths that may be site cut to suit required door width.

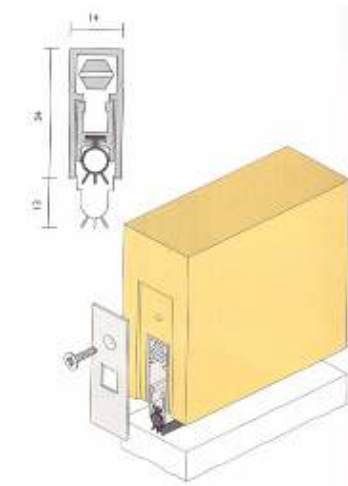

Size:	Code:
600-381mm	<b>IB2206,SA</b>
820-601mm	<b>IB2208,SA</b>
915-821mm	<b>IB2209,SA</b>
1070-916mm	<b>IB2210,SA</b>
1200-1071mm	<b>IB2212,SA</b>

Threshold contact section. For improved sealing when using the automatic door base seals in situations having carpeted floors.

An extruded silver anodised aluminium section for screw fixing across the threshold either with through carpet or used to secure a joint in the flooring. A secondary self adhesive section is then inserted to conceal fixings.

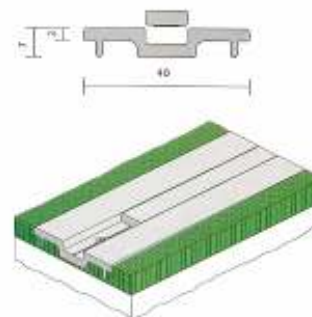

Size:	Code:
1000mm	<b>IB2410,SA</b>