

Salto E5000 Smart Card Security Model

saltosystems.com



- Security range: ideal for use on internal and external doors, where a high security level is required. Security that protects against attacks or illegitimate opening attempts without losing the flexibility or control of the system.
- Designed to cover a wide range of solutions through a unique design.
- PC based access control system.
- High security, by using password and encrypted Chip cards instead of copiable Mag. Stripe.
- Extremely weather resistant.
- Salto Pro Access or Hotel Software intuitive and user friendly. Windows 98, 2000 and XP compatible and available in many languages. In case certain language is not available, it could be adapted immediately.
- Salto PMS interface available.
- Slim and aesthetic design of the escutcheon itself. No bulky elements. Blends seamlessly with every building decoration.
- Simple and intuitive peripherals.
- Portable Programming Device (PPD) in order to communicate with the offline units.
- Unlimited numbers of Master cards, with enhanced Staff management functions through the power of the Chip Card and Virtual Net possibilities.

SALTO
inspired access

Salto E5000 Smart Card Security Model

inspired access

Mechanical features

- Tested and approved for 1/2 hour fire rating.
- Escutcheons with electronic control of mortice deadbolt operation. Access given through Chip Card insertion.
- Hardened steel anti-drill plates.
- Inside always allows opening (anti panic in combination with lock).
- Simple off line installation, on any kind of door, including narrow style frames.
- Wire free system.
- Batteries allow autonomy of 3-4 years (30.000 openings).

Electronic features

- Electronic escutcheon E5000, Security, Smart.
- Uses a range of ISO smart memory cards.
- Non volatile memory (is not deleted, even without power).
- Escutcheons are equipped with a low consumption real time clock function, which allows time zones access planning and the use of 10 different calendars.
- Office mode available (free access mode).
- Dual colour LED (green/red) to indicate lock authorisation. Special blink indication when lock is in privacy mode. Possibility to enable/disable the acoustic signal.

- Low battery indication at the lock and through software (battery status info is written on management Smart Cards).

All weather features

- Reader drain to eliminate water from the reader.
- Reader gaskets to protect the reader from water entry.
- Back plate gaskets to protect PC Board from water entry.

Handles



U Model

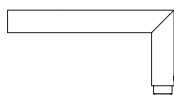

W Model

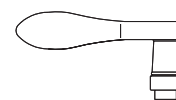

O Model

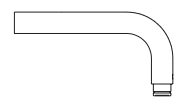

L Model

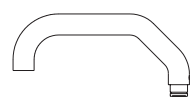

H Model

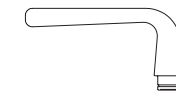

K Model



Finishes



SATIN/POLISHED
STAINLESS STEEL



WHITE
(POWDER COATED)



BLACK
(POWDER COATED)



POLISHED BRASS



SATIN BRASS



ANTIQUE BRASS

U, L, W, H handles available

L, K, O handles available

Salto E5000 Smart Card Security Model

inspired access

Accessories & Software

- Portable Programming Device (PPD).

A messenger between the door and the PC. It is used to initialize the locks, and allows for emergency opening in case batteries of power failure.

- Smart Card Encoder.

Super fast and compact electronic device which eliminates the need for bulky expensive motorised encoder units. RS232 version or ethernet version.



PPD



Smart Card Encoder

- Pro Access Software.

Extremely intuitive and user friendly, it allows to manage all the features of a full access control system. Main features allow to program in access time zones for each user, take into account different company calendars, obtain audit-trails and it includes special functions like automatic changes of the door status.



Pro Access Software

- Salto Hotel Software.

Extremely intuitive and user friendly for check in staff and includes easy to manage back office screens. The front desk provides at a glance all check-in/out functions. Includes several PMS protocols and ethernet encoder communication menu.



Hotel Software (HAMS)

Models Range

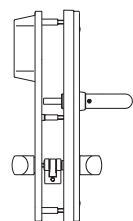
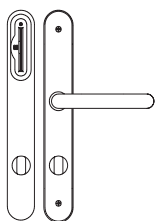

Model E5020
Electronic Escutcheon
E5000 Security Smart.
Inside handle, any type.
Thumbturn on both sides
(outside with clutch
mechanism).

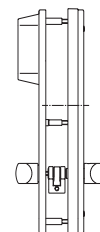
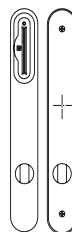

Model E5029
Electronic Escutcheon
E5000 Security Smart
No handles.
Thumbturn on both sides
(outside with clutch
mechanism).

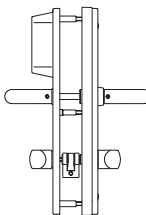
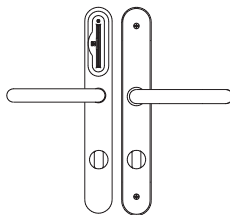

Model E5021
Electronic Escutcheon
E5000 Security Smart.
2 handles, any type.
Thumbturn on both sides
(outside with clutch
mechanism).

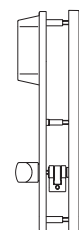
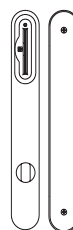

Model E5040
Electronic Escutcheon
E5000 Security Smart
No handles.
Outside thumbturn with
clutch mechanism.

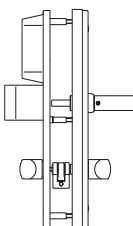
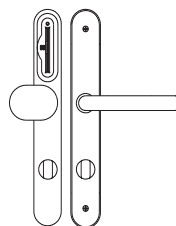

Model E5022
Electronic Escutcheon
E5000 Security Smart
inside handle, any type.
Angled pull handle on outside
Thumbturn on both sides
(outside with clutch
mechanism).

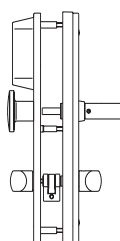
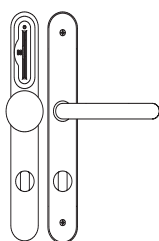

Model E5023
Electronic Escutcheon
E5000 Security Smart
Inside handle, any type.
Fixed knob on outside.
Thumbturn on both sides
(outside with clutch
mechanism).

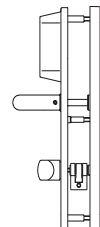
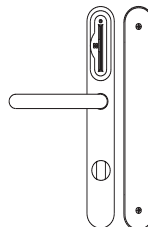

Model E5041
Electronic Escutcheon
E5000 Security Smart
Outside handle, any type.
Outside thumbturn with
clutch mechanism.

Salto E5000 Smart Card Security Model

inspired access

Technical features

- Up to 64000 users.
- Locking plan up to 64000 doors.
- Audit trail: Storage of 1000 last events in non volatile flash memory.
- Power supply: 3 alkaline batteries LR03 AAA 1,5V.
- Temperature range.
 - external escutcheon: -20° / 70° C.
 - internal escutcheon: 0° / 50° C.
- 1/2 hour fire rating, including according DIN.

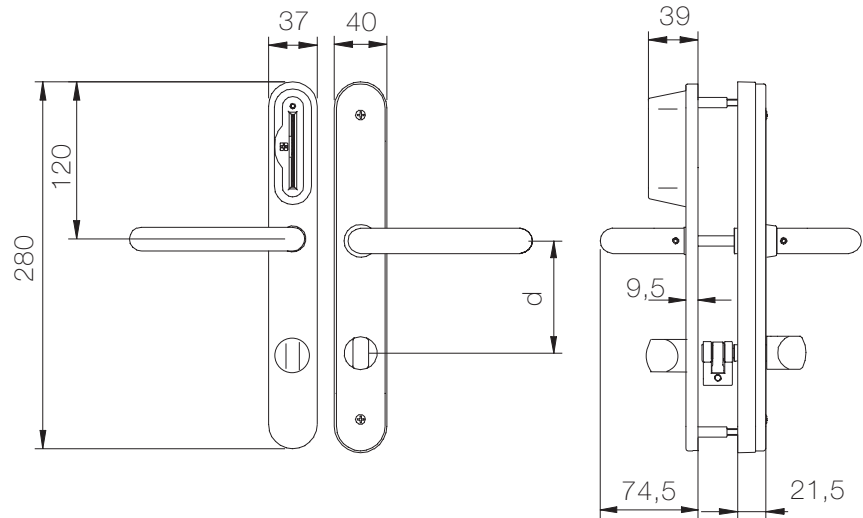

Available Smart Card Carriers

- 256 Bytes memory Card: Password protected, non copiable.
 - 192 Bytes memory Card: Encrypted, non copiable.
 - 2 Kbytes memory Management Card: High Capacity encrypted, non copiable management card. Highly suitable for Salto Virtual Network options, like on-card audit trails.
- Building/Hotel logo and publicity can be printed on card.



SALTO
inspired access

SALTO Systems

Txatxamendi, 26 - Pol.110 - 20100 LEZO Gipuzkoa · Tel.: +34 943 344 550 - Fax +34 943 341 621
e-mail: info@saltosystems.com - www.saltosystems.com